

TE (泰科) 2-231652-1 **PDF**



AUTHORIZED DISTRIBUTOR

深圳创唯电子有限公司

<http://www.te-ec.com>

PROPER USE GUIDELINES

Cumulative Trauma Disorders can result from the prolonged use of manually powered hand tools. Hand tools are intended for occasional use and low volume applications. A wide selection of powered application equipment for extended-use, production operations is available.

1. INTRODUCTION

Modular Plug Hand Tools 231652-[] (shown in Figure 1) are designed to terminate modular plug connectors onto stranded or solid, shielded or unshielded flat oval cable or round cable. The tool also cuts and strips unshielded flat oval cable. Other cable must be prepared by separate tools.

Each tool includes Die Set 853400-[] (see Figure 2), except Tool 2-231652-0 which is available without a die set. The die sets are also available separately.

NOTE All numerical values in this instruction sheet are in metric units [with U.S. customary units in brackets]. Dimensions are in millimeters [and inches]. Figures are not drawn to scale.

Reasons for reissue of this instruction sheet are provided in Section 8, REVISION SUMMARY.

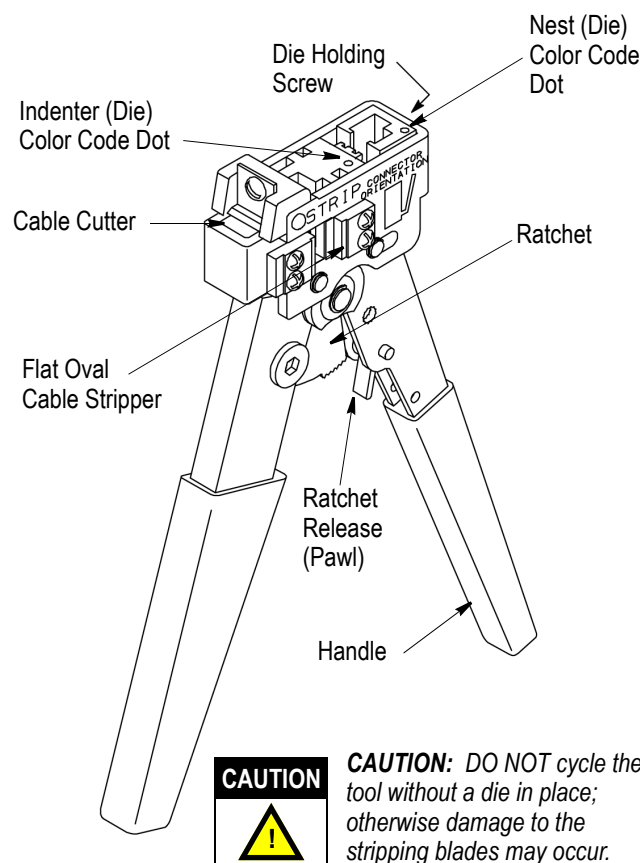

Figure 1

2. DESCRIPTION (Figure1)

The die set consists of a nest and an indenter, each marked with a color-code dot. The die set is held in the tool by a single die-holding screw. Each die set is unique to its purpose, but die sets can be interchanged to accommodate any modular plug. Refer to Figure 2.

The tool features a wire cutter and flat oval cable stripper to prepare unshielded flat oval cable. The tool handle ensures full crimping. Once engaged, the ratchet will not release until the handles have been FULLY closed, unless the ratchet release (pawl) is depressed to manually release the ratchet. When depressed, the pawl prevents crimping of an improperly positioned modular plug.

TOOL	CORRESPONDING DIE SET		
	PART NUMBER	COLOR CODE DOT	DESCRIPTION (Modular Plug Type)
2-231652-1	853400-1	Black	8-Position Line, Blue (Small Conductor), Keyed, Non-Keyed [■] , Shielded
2-231652-3	853400-3	Green	4-Position Handset
2-231652-6	853400-6	Orange	6-Position Offset Latch
2-231652-7	853400-7	Violet	6-Position Long Body
2-231652-8	853400-8	Blue	2-, 4-, 6-Position Line, Blue (Small Conductor)
3-231652-0	1-853400-0	White	8-Position High Performance
3-231652-5	1-853400-3	Red	8-Position Line, Blue (Small Conductor), Non-Keyed [■]
3-231652-6	1-853400-4	Gray	8-Position Slimline Cat6/6A

[■] The BLACK color-coded tool and die set can be used for non-keyed modular plugs; however, the RED color-coded tool and die set are more durable when crimping non-keyed modular plugs.

Figure 2



The dies bottom before the ratchet releases. This feature ensures maximum electrical and tensile performance of the crimp. DO NOT re-adjust the ratchet.

3. CABLE PREPARATION

Refer to Figure 3, and select the appropriate cable and die set for the modular plug being used. Then proceed as follows:

3.1. Unshielded Flat Oval Cable (Figure 4)

1. Insert cable squarely into CUT slot in tool cable cutter. Squeeze handles until ratchet releases.
2. Insert trimmed cable into STRIP slot in tool flat oval cable stripper until cable butts against die cable stop.
3. Close handles to last ratchet stop, but DO NOT release them. Pull cable straight out of tool. Then release tool handles.



DO NOT squeeze handles together while pulling cable out. Rather, with handles closed (but not released) grip head of tool in one hand and cable in the other; then pull cable straight out of tool.

4. Check cable strip length as shown in Figure 4.

3.2. Shielded Flat Oval Cable and Round Cable

Prepare the cable according to Application Specification 114-6016.

3.3. High Performance Cable

Prepare the cable according to Application Specification 114-6053.



DO NOT cut or remove insulation from individual conductors. This may result in shorted or open terminations within the terminated assembly.

4. TERMINATION PROCEDURE

Before proceeding with the termination procedure, check to make sure that the cable and modular plug are compatible, and that cable polarity is correctly maintained for the specific application.

Before proceeding with the termination procedure for high performance modular plugs, refer to 114-6053 for preparation techniques to ensure high performance levels.

Refer to Figure 5, and proceed as follows:

1. Hold modular plug as shown (locking latch facing UP). Insert cable into modular plug until fully bottomed
2. Open tool handles. Insert modular plug assembly fully into die cavity. When using a die set color coded with green, orange, or blue, make sure that the modular plug locking latch snaps into position.

When using a die set color coded with black, violet, or white, make sure that the modular plug bottoms in the die cavity but the locking latch does not snap into position.

MODULAR PLUG		CABLE●		DIE SET COLOR CODE DOT
POSITION	TYPE●	TYPE	STYLE	
2	Line	Stranded	Flat Oval	Blue
4	Handset	Solid	Flat Oval	Green
		Stranded		
	Line	Stranded	Flat Oval	Blue
		Blue		
6	Line	Solid	Round	Blue
		Stranded	Flat Oval	
	Blue	Solid	Flat Oval	Orange
	Offset Latch	Solid		
	Long Body Unshielded	Solid	Flat Oval	Violet
		Stranded	Round	
Long Body Shielded	Stranded	Flat Oval		
8	Unshielded	Stranded	Round	Black■
		Solid	Flat Oval	
		Stranded		
	Blue	Solid	Round	
	Keyed, Non-Keyed	Stranded	Flat Oval	
	Shielded	Stranded	Round	
	Non-Keyed	Stranded	Flat Oval	
8 (High Performance)	Unshielded	Stranded	Round	White
		Solid		
	Shielded	Solid		
		Stranded		
8 Slimline	Unshielded	Stranded	Round	Gray
		Solid		
	Shielded	Stranded		
		Solid		

- Standard modular plugs are designed to be used with cable having an outside diameter of 0.89 to 0.99 mm [.035 to .039 in.]. Use blue (small conductor) modular plugs with cable having an outside diameter of 0.74 to 0.86 mm [.029 to .034 in.].
- Refer to Note (■) at the bottom of Figure 2.

Figure 3



Failure to fully seat the modular plug assembly in the die cavity will cause the indenter to mis-align with the internal strain reliefs of the modular plug, which may result in damage to the die set.

Cutting and Stripping Unshielded Flat Oval Cable

Step 1

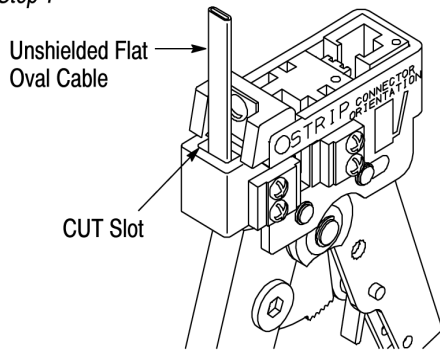

Step 2

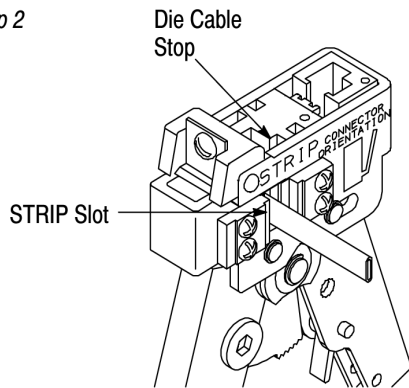

Step 3

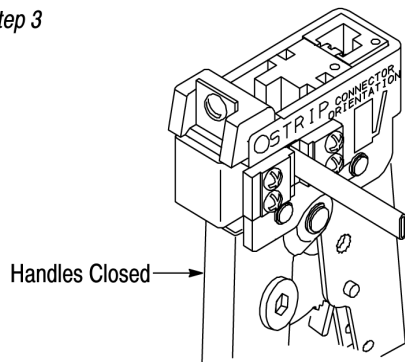

Step 4

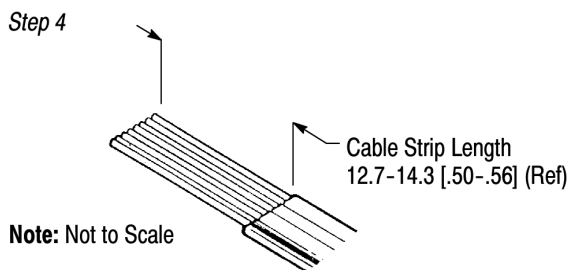



Figure 4

Terminating Modular Plug

NOTE

Illustrations for termination procedure show line modular plugs. Illustrations for other types of modular plugs would be similar.

Step 1

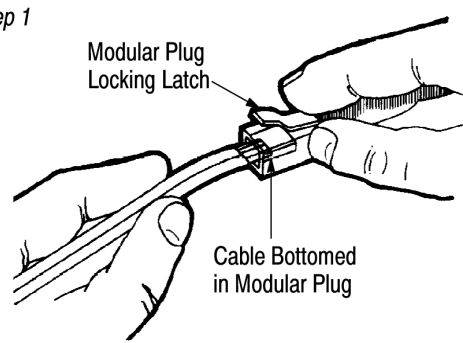

Step 2

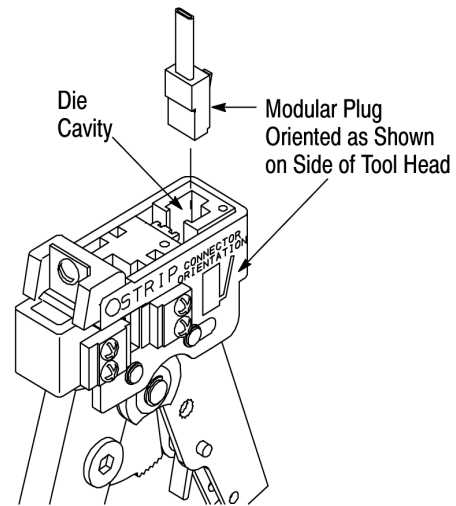

Step 3

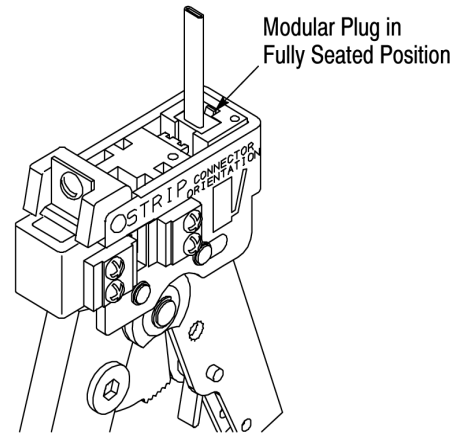

Figure 5

3. Hold the modular plug in the fully seated position, and squeeze tool handles until ratchet releases.

NOTE When crimping, make sure to hold the modular plug in the fully seated position to prevent the modular plug from pushing out during the termination procedure.

4. Depress the modular plug locking latch (if applicable), and remove terminated modular plug assembly from the tool.

5. Inspect the modular plug assembly for proper crimp height using a dial indicator or digital indicator with needle-point probes or Crimp Height Gage 904170-1 according to 408-4389. Figure 6 shows a cross-section of a typical terminated modular plug, proper crimp height dimension, and required location of the conductors. A visual inspection through the plastic housing of the modular plug should reveal whether the conductors are within acceptable range.

NOTE For specific information concerning inspection requirements, refer to 114-6016 for standard and blue (small conductor) modular plugs and 114-6053 for high performance modular plugs.

Terminated Modular Plug Inspection
Cross Section of Crimped Modular Plug

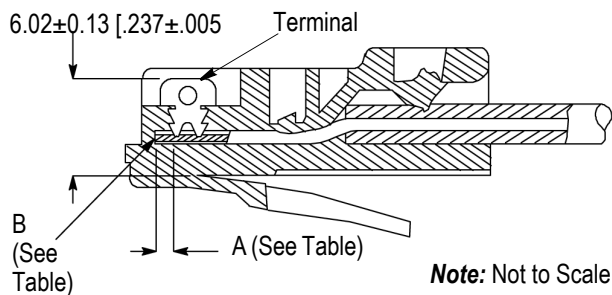

MODULAR PLUG TYPE	CONDUCTOR LOCATION	
	A (Reference Zone)	B (Preferred)
Standard and Blue (Small Conductor)	0.00 - 0.64 [.000 - .025]	Conductors Against End of Wire Circuits
High Performance	0.00 - 0.25 [.000 .010]	

Figure 6

CAUTION Once a termination has been made, DO NOT re-terminate the modular plug. Replace damaged modular plugs with new ones.

NOTE Crimp Height Gage 904170-1 is available to be used as a quick verification of acceptable crimp height as shown in Figure 7. Refer to 408-4389 for instructions on using the gage.

Note: The gage cannot be used for 4-position handset and 6-position offset modular plugs.

Checking Crimp Height

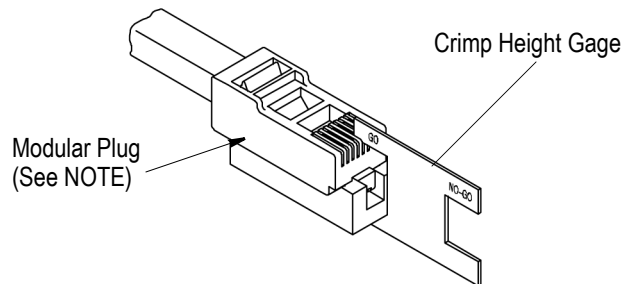

Figure 7

5. ADJUSTMENTS

5.1. Installing, Replacing, or Changing Die Set

1. Squeeze tool handles until ratchet releases.
2. Using a small flat blade screwdriver or cross-recessed screwdriver, remove the die holding screw (turn the screw counterclockwise).
3. Using the screwdriver, push the die set out of the tool.
4. Insert the die set with the color dots facing outward as shown in Figure 1.
5. Close the tool handles. Re-install the die holding screw (turn the screw clockwise until tight).

5.2. Adjusting Flat Oval Cable Stripper (Figure 8)

If cable jacket is cut too shallow and does not strip properly from the conductor bundle or if it is cut too deeply and conductor insulation is also cut, adjust the flat oval cable stripper on the tool according to the following.

NOTE The die set must be in the tool when adjusting the flat oval cable stripper.

1. Close tool handles until the dies bottom, but DO NOT release the handles.
2. Loosen the two screws that hold the movable blade assembly.
3. Insert Blade Set-Up Gage 231667-2 (available separately and part of Blade Replacement Kit 231662-4) or a 1.02-mm [.040-in.] shim between the stationary and movable blades. Slide the movable blade against the gage or shim, and tighten the screws.

NOTE  The recommended shim thickness does not account for larger than normal conductor insulation. Adjust the blade gap according to your specific needs.

Adjusting Flat Oval Cable Stripper

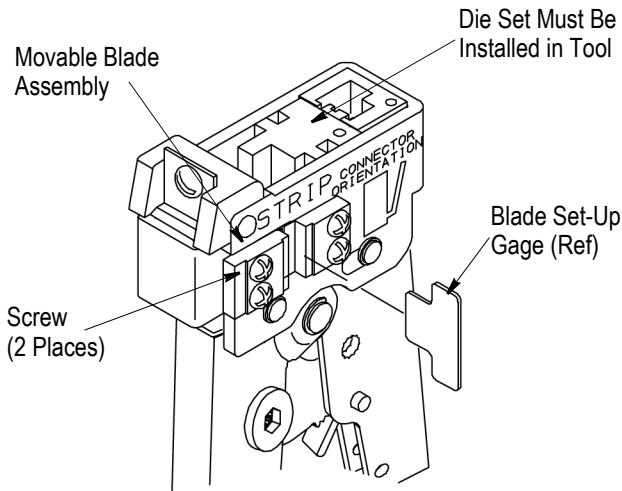

Replacing Blades in Flat Oval Cable Stripper

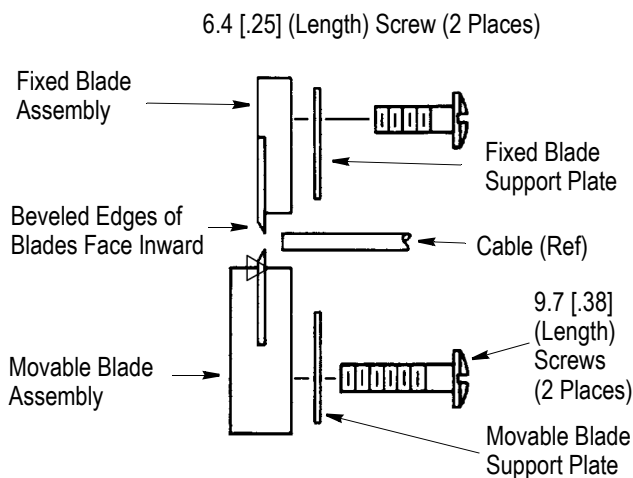

CAUTION: DO NOT cycle the tool without a die in place.

Figure 8

5.3. Replacing Flat Oval Cable Stripper Blades (Figure 8)

If the flat oval cable stripper blades are worn or damaged, replace the fixed blade assembly and movable blade assembly according to the following.

1. Remove the four screws holding both blades in place. Remove fixed blade assembly and movable blade assembly from tool.

2. Position new blades onto tool with beveled edges facing inward.

3. Install and tighten screws. Adjust flat oval cable stripper according to Paragraph 5.2.

CAUTION  DO NOT cycle the tool without a die in place; otherwise, damage to the stripping blades may occur.

6. MAINTENANCE AND INSPECTION

Inspect the tool and die set immediately upon arrival at your facility and at regularly-scheduled intervals thereafter to ensure that they have not been damaged. When not in use, store tool with handles closed in a clean, dry area.

CAUTION  Failure to perform daily maintenance and periodic inspection can cause defective modular plug terminations, leading to discontinuities on individual wire circuits.

6.1. Daily Maintenance

Foreign particles should be cleaned from the tool using a soft, clean, lint-free cloth or brush. Make sure all pins, rings and other retaining hardware is in place, and that the die set is undamaged. Lightly lubricate all pins, pivot points, and bearing surfaces using a good grade SAE 20 motor oil. DO NOT lubricate excessively.

CAUTION  DO NOT lubricate surfaces of the die set that contact the product. These areas must be kept clean to ensure a usable modular plug assembly.

6.2. Periodic Inspection

It is recommended that the following inspections be conducted at least once a month by quality control personnel. More frequent inspections should be conducted if your work environment, company standards, or amount of tool use indicates the need.

A. Visual Inspection

Remove die set from the tool; then, remove all lubrication and accumulated film and debris by immersing the dies and tool head in a mild commercial degreaser.

1. Check for missing or defective pins, rings, or other retaining hardware. Replace parts as necessary.
2. Closely inspect dies for damage, giving special attention to bearing surfaces and surfaces that contact the product. Worn, cracked, pitted, or chipped indenter or nest surfaces, or other obvious wear or damage to the die set or tool head requires removal of the affected part from service.

B. Die Closure Inspection

The tool and die set is inspected for proper operation before shipment. To ensure uniform performance over the life of the tool, periodically inspect as follows:

1. Insert a properly stripped cable of appropriate type and size into a sample modular plug. Then insert the unterminated cable and plug into the die cavity.
2. Squeeze tool handles together slowly, while watching to ensure indenter bottoms against nest.
3. Release handles to open die set, and remove terminated modular plug assembly.
4. Test for proper crimp height according to Section 4, Step 4. If plug crimp height is within acceptable limits, lightly lubricate the tool and die set, and place it back into service. If the crimp height is not within acceptable limits, return the tool (with die set) for evaluation (refer to Section 7).

7. REPLACEMENT AND REPAIR

Customer-replaceable parts are provided in Figure 9. The blade replacement kit and hand tool kits are available separately. Refer to Figure 10 for a description of each. A complete inventory should be stocked and controlled to prevent lost time when replacement of parts is necessary. Order replacement parts through your representative, or call 1-800-526-5142, or send a facsimile of your purchase order to 717-986-7605 or write to:

CUSTOMER SERVICE (038-035)
TYCO ELECTRONICS CORPORATION
PO BOX 3608
HARRISBURG PA 17105-3608

For tool evaluation and customer repair service, call 1-800-526-5136.

8. REVISION SUMMARY

Since the previous release of these instructions, the new company logo has been applied.

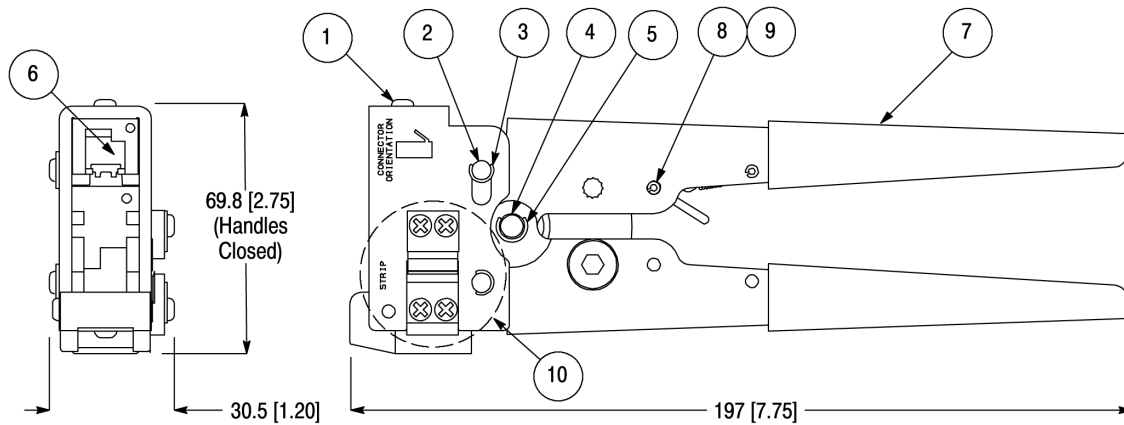

Weight: .3 kg [.75 lb] (Approx)

ITEM	PART NUMBER	DESCRIPTION	QTY PER TOOL
1	993314-1	SCREW, Pan Head ((Die Holding) 4-40 X .250 L	1
2	4.23619-8	PIN, Grooved	2
3	21045-3	RING, Retaining, Crescent	4
4	2-23620-5	PIN, Center, Straight	1
5	21045-6	RING, Retaining, Crescent	2
6	853400-[] †	DIE SET	1
7	2-231652-0	TOOL ASSEMBLY, Frame Without Die Set)	1
8	21045-1	RING, Retaining, Crescent	2
9	768522-1	PIN, Handle (Pawl)	2
10	231662-4	BLADE REPLACEMENT KIT	1

† Refer to Figure 2 for cross-reference of tools to die set part numbers.

Figure 9

KIT PART NUMBER	KIT DESCRIPTION
231662-4	BLADE REPLACEMENT KIT -- Blade Set-Up Gage, 4 Pan Head Screws, 1 Cutter Blade Screw, 5 Wire Cutter Blades, 5 Fixed Blade Holders, 5 Slider Blade Assemblies
231666-9	HAND TOOL KIT -- Carrying Case, Screwdriver, Set of Strip Blades, Cutoff Blade, 2 Support Plates, and 4 Pan Head Screws
1-231665-0	HAND TOOL KIT -- Carrying Case, Screwdriver, Set of Strip Blades, Cutoff Blade, 2 Support Plates, and 4 Pan Head Screws, Modular Plug Hand Tool, 4- and 6-Position Line Die Set, and 8-Position Die Set
1-231666-1	HAND TOOL KIT -- Carrying Case, Screwdriver, Set of Strip Blades, Cutoff Blade, 2 Support Plates, and 4 Pan Head Screws, Modular Plug Hand Tool, 4- and 6-Position Line Die Set, and 8-Position Die Set, and 4-Position Handset Die Set
1-231666-2	HAND TOOL KIT -- Carrying Case, Screwdriver, Set of Strip Blades, Cutoff Blade, 2 Support Plates, and 4 Pan Head Screws, Modular Plug Hand Tool, 4- and 6-Position Line Die Set, and 8-Position Die Set, and 6-Position Long Body Die Set
1-231666-3	HAND TOOL KIT -- Carrying Case, Screwdriver, Set of Strip Blades, Cutoff Blade, 2 Support Plates, and 4 Pan Head Screws, Modular Plug Hand Tool, 4- and 6-Position Line Die Set, 8-Position Die Set, 6-Position Long Body Die Set, and 4-Position Handset Die Set
1-231666-4	HAND TOOL KIT -- Carrying Case, Screwdriver, Set of Strip Blades, Cutoff Blade, 2 Support Plates, and 4 Pan Head Screws, Modular Plug Hand Tool, 4- and 6-Position Line Die Set, 8-Position Die Set, 6-Position Long Body Die Set, and 8-Position High Performance Die Set

Figure 10